

Manuscript received July 17, 2021; revised October 10, 2021; accepted October 11, 2021; date of publication October 1, 2021;

Digital Object Identifier (DOI): 10.35882/TEKNOKES.v1i1.2

This work is an open-access article and licensed under a Creative Commons Attribution-ShareAlike 4.0 International License ([CC BY-SA 4.0](https://creativecommons.org/licenses/by-sa/4.0/))



Digital Pressure Meter Equipped with Pressure Leak Detection

Septian Nur Wahyu Erdyansyah, Torib Hamzah, and Dyah Titisari

¹Departement of Electromedical Engineering Poltekkes Kemenkes, Surabaya

Corresponding author: Septian Nur Wahyu Erdyansyah (e-mail: P27838028033@gmail.com).

ABSTRACT A manual sphygmomanometer is an instrument used to measure blood pressure, and consists of an inflatable cuff, a mercury manometer (or aneroid gauge) and an inflation ball and gauge. To assess the condition, accuracy and safety of mercury and aneroid sphygmomanometers in use in general practice and to pilot a scheme for sphygmomanometer maintenance within the district. Therefore, it must be calibrated periodically. This experiment aims to DPM with touchscreen display and measurement data storage using SD Card. Using the MPX 5050GP sensor as a positive pressure sensor to make it easier for user see the pressure value after doing maintenance or calibrate the sphygmomanometer. Requires a maximum pressure of 300 mmHg. This tool is also equipped with a SD Card as external storage. The display used in this module is TFT Nextion 2.8". After conducting measurements of the three comparisons consisting of Multifunction, DPM and mercury tensimeter to 6 times, the smallest result 0 mmHg and the largest results 251.52 mmHg. While the error in mercury tensimeter's of leak test to module and rigel is 0.56% and 0.404%.

INDEX TERMS Calibration, Sphygmomanometer, TFT

I. INTRODUCTION

Mercury-free sphygmomanometers which use auscultation for the determination of blood pressure have the same limitations as mercury sphygmomanometers[1]. Sphygmomanometer comes from two words, namely Sphygmo (Greek) which means beat and manometer which means pressure gauge[2]. Along with the development of technology in the field of medical equipment, sphygmomanometers have developed from mercury sphygmomanometer, needle sphygmomanometer, and the latest is digital sphygmomanometer[3]. The sphygmomanometer calibrator is a tool to test the level of precision with standard values for measuring blood pressure on a sphygmomanometer[4]. Sphygmomanometer or Blood Pressure Meter is an instrument used to measure arterial blood pressure pressure that works manually or automatically (Non Invasive) in the pumping or reduce pressure on the cuff with a non-invasive system. with the help of a stethoscope There are 2 kinds of blood pressure, namely systolic and diastolic . Accurate measurement of blood pressure (BP) is mandatory for proper diagnosis and follow-up [5]. Discussions such as the correct method, the most common errors, the size and the proportion of fixed cuffs in the search for more reliable measuring devices that show patients' true

blood pressure[6] A manual sphygmomanometer is an instrument used to measure blood pressure, and consists of an inflatable cuff, a mercury manometer (or aneroid gauge) and an inflation ball and gauge [7]. To assess the condition, accuracy and safety of mercury and aneroid sphygmomanometers in use in general practice and to pilot a scheme for sphygmomanometer. maintenance within the district [8]. Therefore, it must be calibrated periodically. To maintain the accuracy of the sphygmomanometer value, periodic calibration is needed. Errors in blood pressure measurement can be caused by human error or the function of the device itself whose accuracy has exceeded the allowable threshold (Standard error of up to 3 mmHg)[6]. The tool for calibrating the sphygmomanometer is a Digital Pressure Meter (DPM)[9]. Calibration is a technical activity consisting of determination, determination of one or more properties and characteristics of a product, process or service in accordance with a specific procedure that has been determined. The purpose of calibration is to ensure that the measurement results comply with national and international standards[10]. Digital Pressure Meter (DPM) is a tool used to measure positive and negative pressure on medical devices in liquid or gas form to assist in quality improvement and control. One of the tools used for pressure calibration is the digital pressure

meter, which is the function of this tool to measure pressure on the sphygmomanometer and suction pump or other tools that use pressure parameters for measurement [11]. The way this tool works is by converting the value of the pressure sensor to be changed and displayed on the display. In 2016 Novella Lasdrei Anna L. conducted a study entitled digital pressure meter equipped with a pc-based thermohygrometer which aims to facilitate users and speed up the calibration process, while also reducing the possibility of errors in entering data [9]. This tool already has a fairly small error value, but this tool is still not efficient enough to be used as a digital pressure meter. In 2017 Junia Dyah Permata Wibisono has conducted a research entitled digital pressure meter (dpm) vacuum pressure by using which is also equipped with a hold button and conversion selection using Kpa units [12] but this tool is not equipped with data storage. In 2019 Ketut Dyah Kusumadewi conducted a research entitled two mode dpm equipped with a thermohygrometer and positive pressure. This tool has been equipped with negative pressure measurements and unit selection at positive pressure [13]. However, this tool is not equipped with data storage.

studies indicate that substantial proportions of sphygmomanometers in general practices and hospitals exhibit clinically significant (>3 mmHg) systematic pressure errors and other faults [14].

Based on the above studies, the author will create a digital pressure meter tool using a power bank as a power supply and equipped with external storage using an SD Card which then the results of the measurement data will be displayed on the tft Nextion 2,8". This studies aims to add storage features and display features on TFT screen. With the measurement value storage features it helps the user to see it after taking measurements.

II. MATERIALS AND METHODS

A. EXPERIMENTAL SETUP

This study uses a measurement of a mercury sphygmomanometer with a positive pressure setting; 0mmHg, 50mmHg, 100mmHg, 150mmHg, 200mmHg, 250mmHg. Data collection was repeated 6 times for calibration mode.

1) Materials and tool

The pressure sensor used is the type MPX5050GP are easily available in the market and this type is gauge (not depends on the atmospheric pressure)[15]. This membrane deformation will change the resistivity of piezore- sistor which affects the piezoresistors resistance and output voltage of sensor[16]. This pressure sensor is a monolithic silicon pressure sensor designed for a wide range of applications, especially those using a microcontroller or microprocessor with A/D input[17]. Different amplifier circuit using IC LM358 as a amplifier module.Arduino Nano microcontroller as a data processor. The Arduino Nano has a number of facilities for communicating with a computer, another Arduino, or other microcontrollers[18]. Automatically by the sensor, measurement data are transmitted in a serial mode to Arduino and will be processed by the microcontroller[19]. Data results

will be saved via SD Card V-Gen 4GB and SD Card Module. TFT Nextion as a display. Nextion tools presented by Itead[20]. A mercury Sphygmomanometer (GEA Medical MI-2001) and Rigel Medical UNI-SiM are used as module comparisons.

2) Experiment

In this study, after the design was finished, the Digital Pressure Meter (Positive Pressure) output was tested with pressures of 0mmHg, 50mmHg, 100mmHg, 150mmHg, 200mmHg, 250mmHg, then measured with a Tensimeter. Each setting, was calculated to validate the results of this study. The leak test is carried out by pumping the sphygmomanometer at a certain pressure (200 or 250) and waiting for 1 minute, with a pressure drop of 15 mmHg tolerance.

B. THE DIAGRAM BLOCK

In this study, flow rate data was obtained from the output of Syringe Pump and Infusion pump with several settings namely 10, 50 and 100 mL/h and as shown in **FIGURE 1**. Infrared sensor and photodiode as a liquid detector in the drip chamber tool. The infrared sensor and photodiode output then go into the Arduino Nano ADC pin as controller and controller. The Arduino Nano output will be sent using the Bluetooth Module HC-05 then displayed on the PC using PLX DAQ.

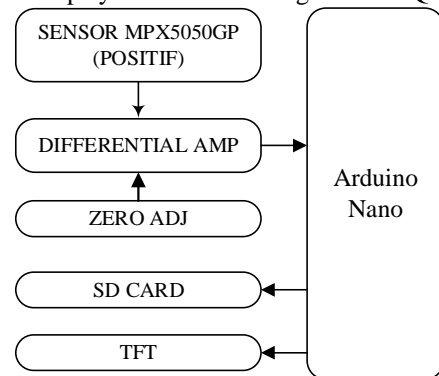

FIGURE 1. Diagram Block

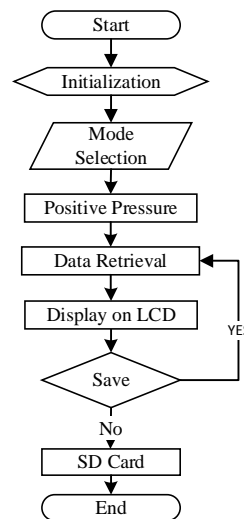

FIGURE 2. The Flowchart of Positive Pressure

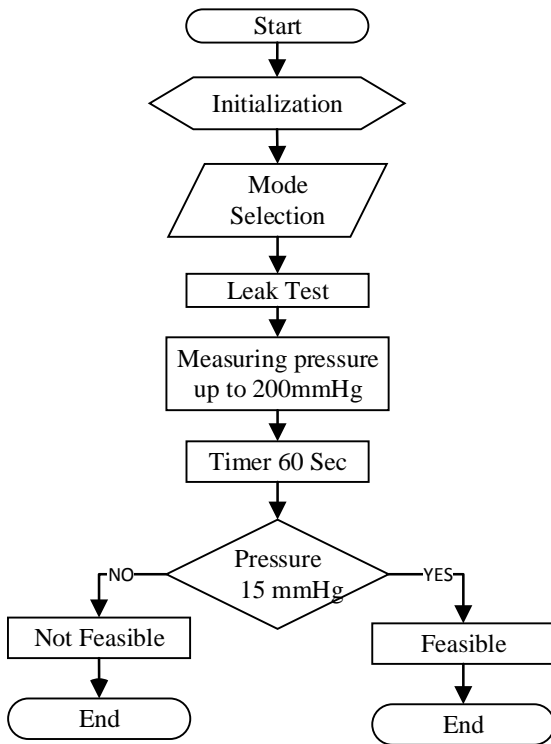

FIGURE 3. The Flowchart of Leak Test

C. THE FLOWCHART

The Arduino program was built based on the flowchart as shown in FIGURE 2 and FIGURE 3. When the tool is turned on, program initialization occurs. There are 2 modes to choose, namely positive pressure (calibration) and leak test. At the time of calibration, the sensor will detect pressure data which is then displayed on the TFT Nextion 2.8” display. The data obtained can be stored on the SD Card. During the leak test, pump until the pressure reaches 200mmHg then press the timer button for 1 minute. If the pressure is 15 mmHg, the display will display inappropriate information and vice versa. Turn off the module after use.

D. ANALOG CIRCUIT

1) SENSOR CIRCUIT

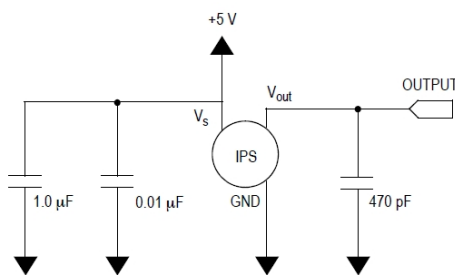

FIGURE 3. Solenoid Valve Drive Circuit

To use this pressure sensor, the MPX5050GP sensor must be coupled with several other components as a power source and a suitable output voltage filter (FIGURE 4).

2) ZERO AJUSTMENT CIRCUIT

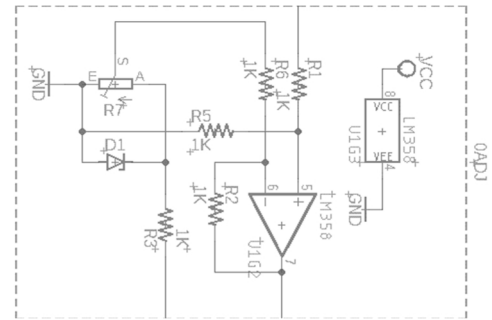

FIGURE 4. Sensor Infrared and Photodiode

The zero adjustment circuit functions to adjust the pressure value so that it can reach a value of 0. The zero adjustment circuit consists of a difference amplifier circuit that utilizes the LM358 Op-Amp IC. The difference amplifier circuit gets input from a series of sensors located at pin 5 (non-inverting) and a voltage division circuit that enters pin 6 (inverting). Setting the value settings needed to produce a value of 0 utilizes the variable resistor component. The output of the difference amplifier value that comes out through pin 7 is a voltage that is converted into the ADC value on the Arduino nano (FIGURE 5).

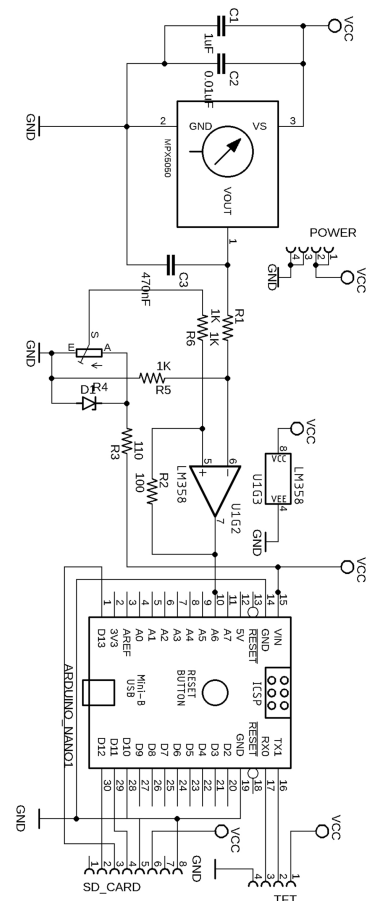

FIGURE 5. Design Module

III. RESULT

In this study, the Digital Pressure Meter has been tested using an Rigel Medical UNI-SiM and GEA medical MI-2001 Mercury Sphygmomanometer.

1) RESULT OF DIGITAL PRESSURE METER

In this study, **FIGURE 5.** shows a series of Digital Pressure Meter final schematics/circuit. The final circuit consist of MPX 5050GP circuit, zero adjustment circuit to set the zero value on a module, and the microcontroller circuit as value modifier and set the display and storage system module

2) THE LISTING PROGRAM FOR ARDUINO

In this program is the MPX5050GP sensor reading to detect positive pressure and enter the ADC pin 6 on the Arduino and convert the pressure kPa to mmHg. The listing program for sensor was shown in the **Pseudocode 1.** This code at once convert the output voltage value to mmHG pressure value.

Pseudocode: 1. Program sensor

```

1. void loop() {
2.   ADC_Tekanan = analogRead(sensor);
3.   nilai_tegangan = ADC_Tekanan*0.00478983;
4.   mmhg = (((nilai_tegangan/5.0)-0.04)/0.018)*7.5)-1;

```

3) THE LISTING PROGRAM DATA STORAGE

In order to DPM can save data when calibrating the sphygmomanometer. The listing program for data storage was shown in the **Pseudocode 2.** SD card is used to store the data that has been taken. During calibration mode, the save button functions as a save button and the display on the nextion tft will stop counting for a moment or delay if the data is successfully saved to the sd card.

Pseudocode: 1 Program Data Storage

```

1. File dataku = SD.open("dika.txt", FILE_WRITE);
2.   if (dataku){
3.     dataku.println(count);
4.     dataku.print(" mmHg=");
5.     dataku.println(mmhg2);
6.     dataku.close();
7.     delay(1000);
8.     Serial.println("Data Tersimpan");
9.     count++;

```

4) THE LISTING PROGRAM ON DISPLAY

The initial display when the tool is turned on, there are 2 selection modes, namely calibration mode and leak test mode. List program for display in tft nextion was shown in the **Pseudocode 3.**

Pseudocode: 2 Program On Display

```

1. n4.val++
2. if(n4.val>59) // n4=detik, n5=menit
3. {
4.   n5.val=1
5.   n4.val=0
6.   tm1.en=0
7. }else
8. {
9.   n5.val=0
10. }

```

5) THE LISTING PROGRAM CALIBRATION AND LEAK TEST

The listing program for calibration and leak test was shown in the **Pseudocode 4.** This program determines the sphygmomanometer being tested is suitable for use or not, namely by providing good/leak information on the leak test.

Pseudocode: 3 Program Calibration and Leak Test.

```

1. if (mmhg<0)
2.   if (mmhg>0
3.     if (mmhg>20
4.       if (mmhg>60
5.         String command2 ="dika.txt="
6.         \"+String(mmhg,2)+"\"";
7.         Serial.print(command2);
8.         Serial.write(0xff);
9.         Serial.write(0xff);
10.        Serial.write(0xff);
11.        delay(200);
12.        pin_value=mmhg2;
13.        if(progress_value !=pin_value){
14.          progress_value=pin_value;
15.          if(progress_value>165
16.            Serial.print("t2.txt=\\"BOCOR\");
17.            Serial.write(0xff);
18.            Serial.write(0xff);
19.            Serial.write(0xff);
20.          }
21.          else if(progress_value>185
22.            Serial.print("t2.txt=\\"BAIK\");
23.            Serial.write(0xff);
24.            Serial.write(0xff);
25.            Serial.write(0xff);
26.          }

```

6) THE LISTING PROGRAM TIMER

The listing program for calibration and leak test was shown in the **Pseudocode 5.** This program uses milliseconds as timer. The time it takes is 60 seconds.

Pseudocode: 4 Timer program

```

1. n4.val++
2. if(n4.val>59) // n4=detik, n5=menit
3. {
4.   n5.val=1
5.   n4.val=0
6.   tm1.en=0
7. }else
8. {
9.   n5.val=0
10. }
```

7) MEASUREMENT RESULT

The measurement results on the module are compared with Rigel Medical UNI-SiM and GEA medical MI-2001 Mercury Sphygmomanometer. The module measurement using DPM Rigel Medical UNI-SiM was performed in a Poltekkes Kemenkes Surabaya laboratory. These measurements were made to know the truth of the DPM module. The measurement result was showed in **TABLE I**.

TABLE I
Measurement With Rigel

AVG	STDEV.P	UA
0	0.00	0
50.4	0.16	0.07
101.0	0.10	0.04
149.9	0.19	0.08
201.0	0.24	0.10
251.3	0.16	0.07

TABLE II
MEASUREMENT WITH MERCURY SPHYGMOMANOMETER

Mean (mmHg)	STDEV.P (mmHg)	UA
0.00	0.00	0.00
50.64	0.26	0.11
100.68	0.24	0.10
148.66	0.13	0.05
200.52	0.37	0.15
250.57	0.25	0.10

TABLE I shows the results of the comparison of values between the module and the Rigel Medical UNI-SiM 6 times consisting of 3 measurements of rising pressure and 3 measurements of falling pressure. The module measurement using DPM Rigel Medical UNI-SiM was performed in a Poltekkes Kemenkes Surabaya laboratory. These

measurements were made to know the truth of the DPM module. The measurement result was showed in **TABLE II**. **TABLE II** shows the results of the comparison of values between the module and Mercury Sphygmomanometer Gea Medical MI-2001 for 6 times consisting of 3 measurements of rising pressure and 3 measurements of falling pressure.

TABLE III
THE LEAKAGE TEST

Pengukur	200 mmHg/60s						Rata-Rata
	X1	X2	X3	X4	X5	X6	
Rigel Medical UNI-SiM	196.67	197.14	197.3	196.6	196.9	196.87	196.9
Modul	197.47	197.96	198.23	197.26	197.5	197.66	197.7
Tensimeter	197	198	197	197	198	197	197.3
Modul	195.66	196.23	195.74	195.7	197.5	197.66	196.2

In **TABLE III** Shows the measurement results of the GEA medical MI-2001 Mercury Sphygmomanometer leak test on the module and GEA medical MI-2001 Mercury Sphygmomanometer against the Rigel Medical UNI-SiM for 6 measurements.

TABLE IV
OUTPUT SENSOR MEASUREMENT

Pressure (mmHg)	Output Sensor (volt)	
	UP	DOWN
0	0.17	0.17
50	0.76	0.76
100	1.35	1.36
150	1.96	1.97
200	2.56	2.57
250	3.15	3.15

In **TABLE IV**, the output voltage produced by the mpx5050gp sensor with a supply of 5 volts is between 0.17 volts with a pressure of 0 mmHg to 3.15 volts with a pressure of 250 mmHg.

IV. DISCUSSION

Based on the pressure measurement the sensor circuit with DPM produces output according to the sensor specifications with data collection of 6 sets. That is 0, 50, 100, 150, 200, and 250 for positive pressure in units of mmHg.

Results The output pressure sensor produces a variable and linear voltage each increase and decrease ranging from 0.15-3.15 V. The results of the DPM tool are also compared with Rigel Medical UNI-SiM and GEA medical MI-2001 Mercury Sphygmomanometer tools for detecting Pressure. The value of the error obtained from measurements between Module and Rigel UNI-SiM starting from 0.00% (0), 0,8% (50), 1% (100),

0.0007% (150), 0.5% (200), 0.52% (250). The value of the error obtained from measurements between Module and GEA medical MI-2001 Mercury Sphygmomanometer starting from 0.00% (0), 1.28% (50), 0.68% (100), 0.9% (150), 0.26% (200), 0.23% (250). While for the measurement results of leak test error using Rigel Medical UNI-SiM produce a value of 0.404% and using A mercury Sphygmomanometer (GEA Medical MI-2001) produce a value of 0.56% error.

V. CONCLUSION

Overall, this research concludes that, a Digital Pressure Meter can be made to monitor the performance of the Sphygmomanometer, namely the output in the form of Positive pressure. This research is built based on Arduino Nano, MPX5050GP sensor, differential circuit, 16x4 character LCD. After taking data using the Rigel tool, it can be concluded that the connecting hose between the module output and the comparison hose greatly influences the measurement results. The results of data storage on the SD Card will be displayed in the form of a Notepad (txt) file. From the results of calibration measurements using Rigel Medical UNI-SiM, the smallest error is 0.00% and the largest error is 1% and the error from the leak test is 0.404%. While the measurement results using the GEA medical MI-2001 Mercury Sphygmomanometer, the smallest error is 0.00% and the largest error is 1.28% and the error value from the leak test is compared to the Rigel Medical UNI-SiM which is 0.56%.

REFERENCES

- [1] W. De Jong, P. Hartemann, and M. Thomsen, "Mercury Sphygmomanometers in Healthcare and the Feasibility of Alternatives," *SCENIHR (Scientific Comm. Emerg. New. Identified Heal. Risks)*, no. September, 2009.
- [2] V. A. Tsyrlin, M. G. Pliss, and N. V. Kuzmenko, "The history of blood pressure measurement: from Hales to our days," *Arterial'naya Gipertenz. ("Arterial Hypertens.)*, vol. 22, no. 2, pp. 144–152, 2016.
- [3] G. Suheriono, A. Pudji, and M. R. Makruf, "Kalibrator Tensimeter Dilengkapai Dengan Pengukuran Suhu dan Kelembaban," *J. Teknokes*, vol. 9, no. 1, p. 2, 2016.
- [4] A. Oprasena, "DIGITAL PRESSURE METER SPHYGMOMANOMETER DILENGKAPI SENSOR HSM- 20G BERBASIS MICROCONTROLLER ATMEGA8 TUGAS AKHIR Oleh ;," 2017.
- [5] S. Ghareeb *et al.*, "Results of a project to calibrate mercury sphygmomanometer blood pressure-measuring devices in Egypt," *J. Hum. Hypertens.*, 2020.
- [6] P. Cristina Silva, R. Souza de Faria, A. Goncalves Sallum, L. Vinicius de Alcantara Sousa, V. E. Valenti, and P. Jose Oliveira Cortez, "Analysis of Mercury Sphygmomanometers in A Hospital School-Analysis of Mercury Sphygmomanometers," *J. Cardiol. Ther.*, vol. 5, no. 1, pp. 697–700, 2018.
- [7] M. Ryan, N. Rokhman, B. G. Irianto, and H. G. Ariswati, "DIGITAL PRESSURE METER," vol. 1, no. 1, pp. 1–4, 2019.
- [8] T. Knight *et al.*, "Sphygmomanometers in use in general practice: An overlooked aspect of quality in patient care," *J. Hum. Hypertens.*, vol. 15, no. 10, pp. 681–684, 2001.
- [9] N. L. Anna, A. Pudji, and M. R. Makruf, "Kalibrator Tensimeter Dilengkapai Dengan Thermohyrometer Berbasis PC," *Kalibrator Tensim. Dilengkapai Dengan Thermohyrom. Berbas. PC Nov.*, p. 2, 2017.
- [10] F. F. Rooswita, T. Rahmawati, and S. Syaifudin, "Two Mode DPM Equipped with an Automatic Leak Test Using MPX5050GP and MPXV4115VC6U Sensors," *J. Electron. Electromed. Eng. Med.*

- Informatics*, vol. 3, no. 1, pp. 1–7, 2021.
- [11] B. Utomo, I. D. G. Hariwisana, and S. Misra, "Design a Low-Cost Digital Pressure Meter Equipped with Temperature and Humidity Parameters," *Indones. J. Electron. Electromed. Eng. Med. informatics*, vol. 3, no. 2, pp. 59–64, 2021.
- [12] J. D. P. Wibisono, "Digital Pressure Meter (DPM) Va cum Pressure ,," *Jur. Tek. Elektromedik Politek. Kesehat. KEMENTRIAN Kesehat. SURABAYA*, 2017.
- [13] K. D. Kusumadewi, "DPM Dua Mode Dilengkapi Thermohyrometer dan Pemilihan Tekanan (Positive Pressure)," *Univ. Muhammadiyah Gersik*, vol. 01, pp. 1–7, 2020.
- [14] M. J. Turner, "Sphygmomanometer calibration Why, how and how often?," *Aust. Fam. Physician*, vol. 36, no. 10, pp. 834–837, 2007.
- [15] A. J. Puspitasari, E. Endarko, and I. Fatimah, "Blood Pressure Monitor Design Using MPX5050GP Pressure Sensor and Visual C# 2010 Express," *J. Fis. dan Apl.*, vol. 15, no. 3, p. 99, 2019.
- [16] J.-T. Huang, K.-Y. Lee, and M.-C. Chiu, "CMOS Force Sensor with Scanning Signal Process Circuit for Vertical Probe Card," *Sensors Focus Tactile Force Stress Sensors*, no. December, 2008.
- [17] I. Ayu, D. Satmi, P. C. Nugraha, and T. Rahmawati, "Juni 2017 DPM dengan Pemrosesan Data Otomatis Seminar Tugas Akhir," *DPM dengan pemrosesan data otomatis*, 2017.
- [18] "Arduino Nano V2.3 User Manual," *Arduino*, pp. 1–5, 2008.
- [19] M. R. Z. Fajar, S. Hadiyoso, and A. Rizal, "An interfacing digital blood pressure meter with arduino-GSM module for real-time monitoring," *ICCREC 2017 - 2017 Int. Conf. Control. Electron. Renew. Energy, Commun. Proc.*, vol. 2017–Janua, no. September, pp. 98–102, 2017.
- [20] A. C. Bento, "IoT of Nextion X TFT ILI9341: Experimental Results and Comparative Survey," *Int. Res. J. Eng. IT Sci. Res.*, vol. 4, no. 2, pp. 14–23, 2018.